

AXIAL MILLING AND DRILLING HEAD

TYPE TAKISAWA

軸向鑽銑刀座 (0°)

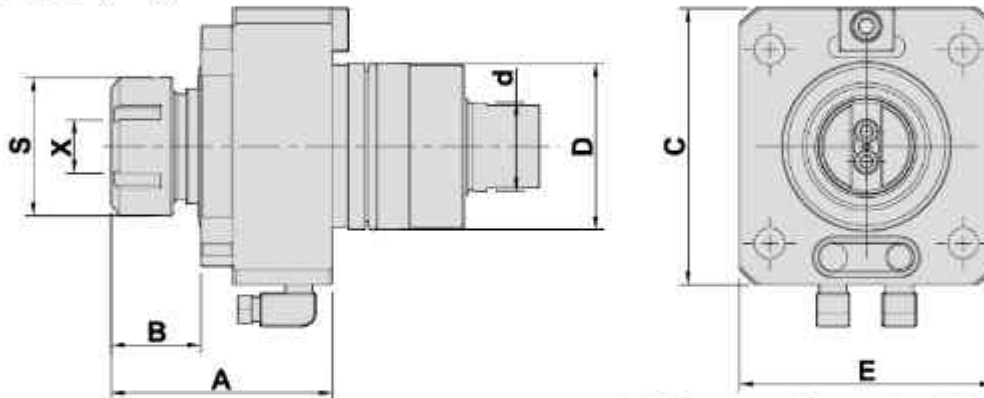

- To be used for collet DIN 6499
- External coolant supply
- Collet is not included

DIMENSIONS

Models	D	X Capacity	S	Maximum R.P.M.	A	B	C	E	d	Code No.	Order No.	(Kg) Weight
EX308 LA-200M LA-250MH LA-200Y LA-250Y LA-250YH	60	2-20 ER32	50	6000	80	32.5	100	92	40	1601KD-000	DA60-K-ER32	4
NEX-108M /FX-800	60	2-20 ER32	50	6000	80	32.5	100	92	32	1601KR-000	S-DA60-K-ER32	4

RADIAL MILLING AND DRILLING HEAD

徑向鑽銑刀座 (90°)

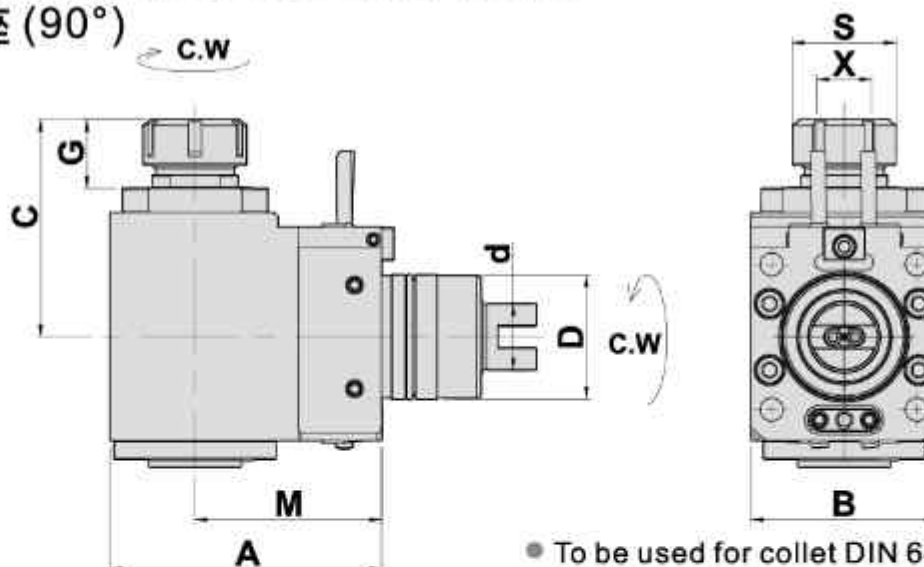

- To be used for collet DIN 6499
- External coolant supply
- Collet is not included

DIMENSIONS

Models	D	X Capacity	S	Maximum R.P.M.	A	B	C	G	M	d	Code No.	Order No.	(Kg) Weight
EX308 LA-200M LA-250MH LA-200Y LA-250Y LA-250YH	60	2-20 ER32	50	5000	131	90	105	34	90	40	2601KA-000	DFL60-K-32-90	10.7
	60	1-13 ER20	35	5000	131	90	101.5	30	90	40	2601KZ-000	DFL60-K-20-90	10.7
NEX-108M /FX-800	60	2-20 ER32	50	5000	131	90	105	34	90	32	2601KA004-000	S-DFL60-K-32-90	10.7

AXIAL MILLING AND DRILLING HEAD

TYPE TAKISAWA

徑向鑽銑刀座 (90°)

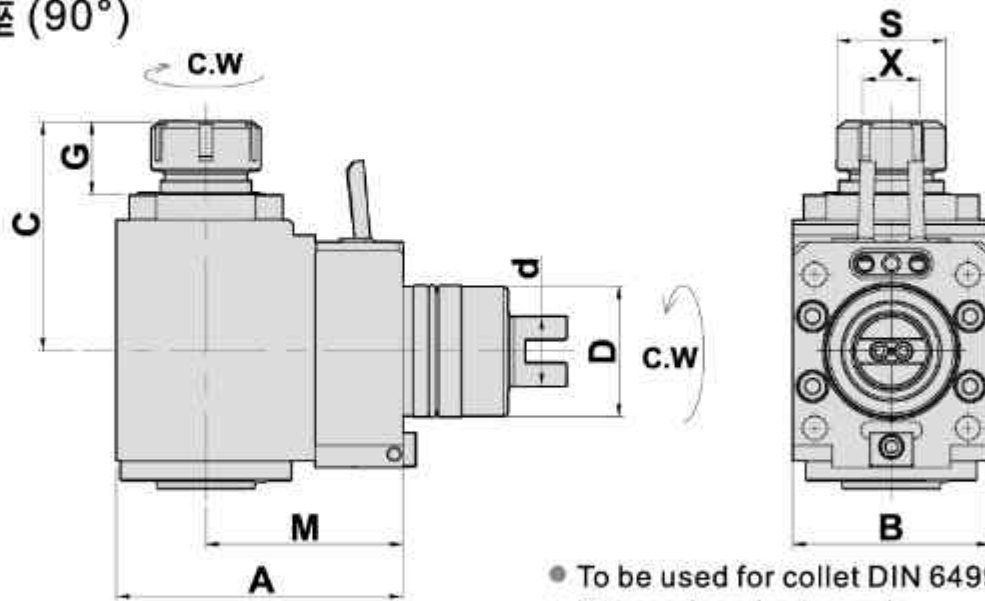

- To be used for collet DIN 6499
- External coolant supply
- Collet is not included

DIMENSIONS

Models	D	X Capacity	S	Maximum R.P.M.	A	B	C	G	M	d	Code No.	Order No.	(Kg) Weight
NEX-108M /FX-800	60	2-20 ER32	50	5000	131	90	105	34	90	32	2601KA005-000	S-DFR60-K-32-90	10.5

RADIAL MILLING AND DRILLING HEAD

徑向鑽銑刀座 (90°)

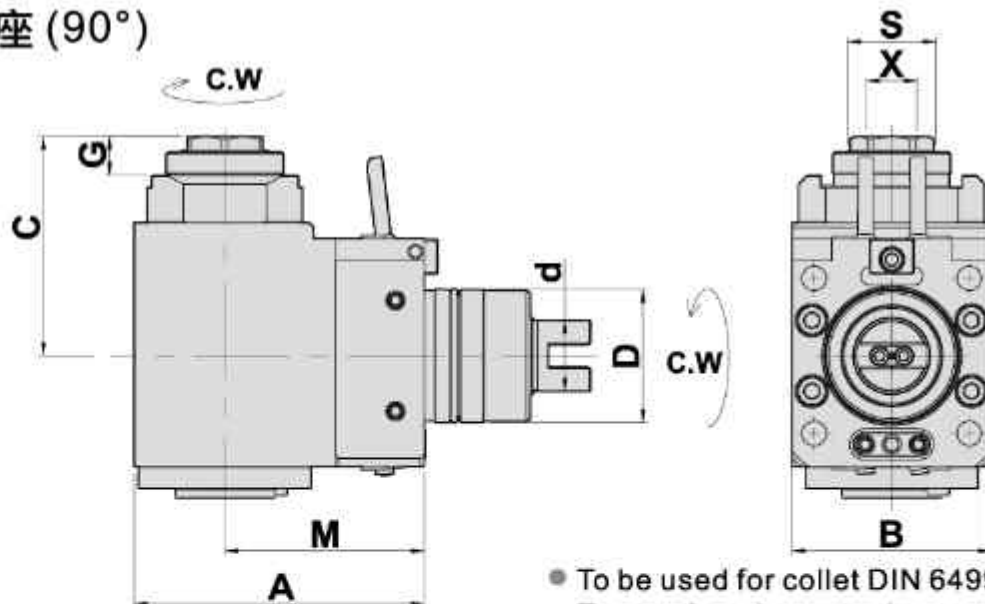

- To be used for collet DIN 6499
- External coolant supply
- Collet is not included

DIMENSIONS

Models	D	X Capacity	S	Maximum R.P.M.	A	B	C	G	M	d	Code No.	Order No.	(Kg) Weight
EX308 LA-200M LA-250MH LA-200Y LA-250YH LA-250YH	60	2-20 ER32A	38	5000	131	90	99	17.5	90	40	2601KN-000	DFL60-K-32A-90-TA	10.9
NEX-108M /FX-800	60	2-20 ER32A	38	5000	131	90	99	17.5	90	32	2601KA006-000	S-DFL60-K-32A-90-TA	10.9

AXIAL MILLING AND DRILLING HEAD OFFSET

TYPE TAKISAWA

軸向側銑刀座 (0°)

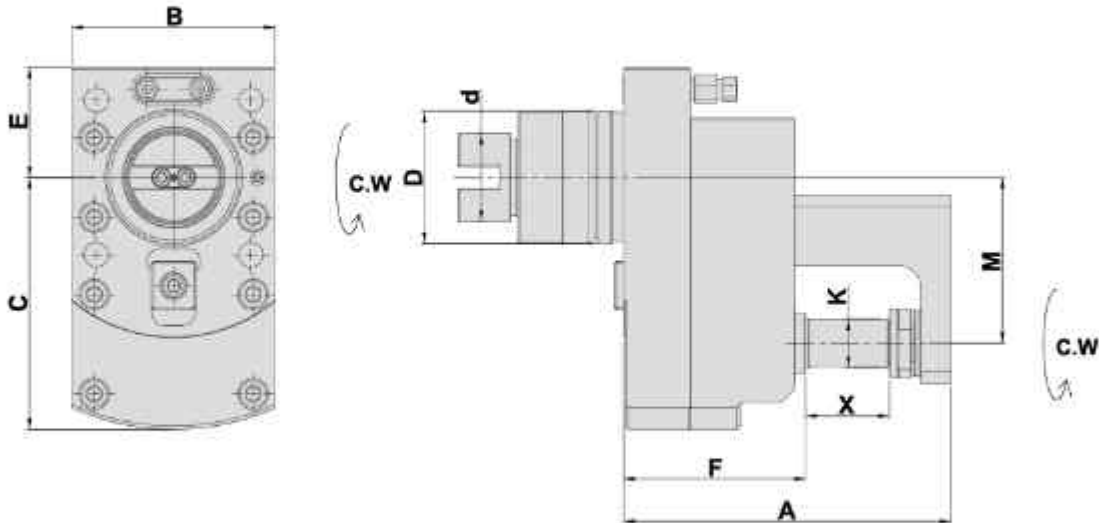

- To be used for collet DIN 6499
- External coolant supply
- Collet is not included

DIMENSIONS

Models	D	X Capacity	Maximum R.P.M.	i	A	B	C	E	F	K	M	d	Code No.	Order No.	(Kg) Weight
EX308 LA-200M LA-250MH LA-200Y LA-250Y LA-250YH	60	38	3000	2:1	148	92	114	50	82	22	75	40	1601KC-000	DA60-K-22C-75I	9.7

* i=2倍減速

AXIAL SHELL AND MILLING CUTTER

軸向銑削刀座 (0°)

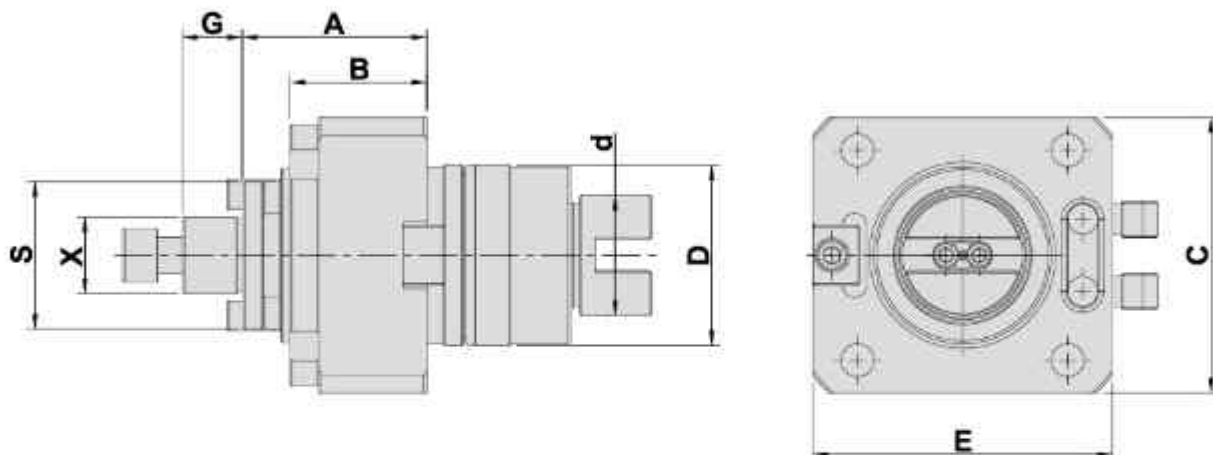

- To be used for collet DIN 6499
- External coolant supply
- Collet is not included

DIMENSIONS

Models	D	X Capacity	Maximum R.P.M.	A	B	C	E	G	S	X	d	Code No.	Order No.	(Kg) Weight
EX308 LA-200M LA-250MH LA-200Y LA-250Y LA-250YH	60	25.4	6000	61.5	47.5	92	100	20	50	25.4	40	1601KF-000	DA60-K-25.4C	4.3

AXIAL MILLING AND DRILLING HEAD

TYPE TAKISAWA

軸向鑽銑刀座 (0°)

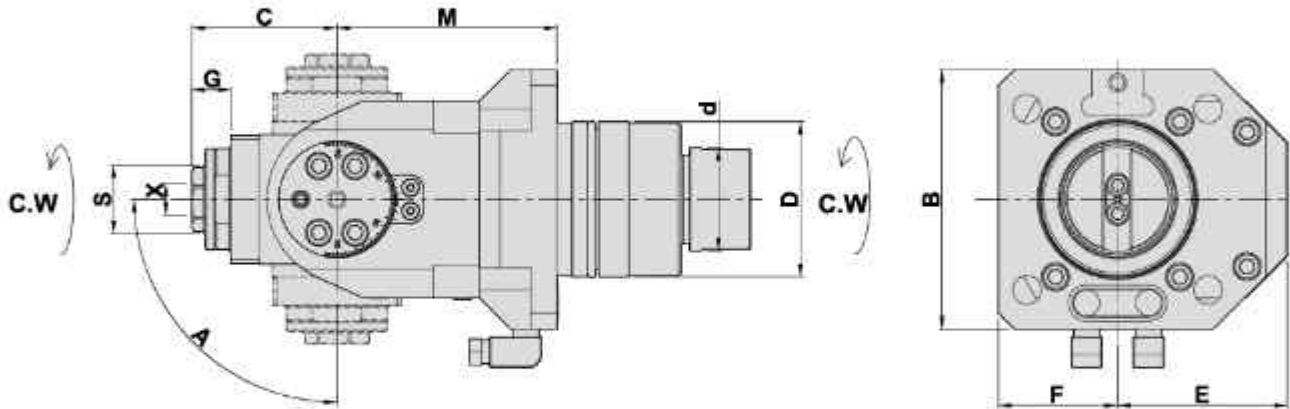

- To be used for collet DIN 6499
- External coolant supply
- Collet is not included

DIMENSIONS

Models	D	X Capacity	S	Maximum R.P.M.	A	B	C	E	F	G	M	d	Code No.	Order No.	(Kg) Weight
EX308 LA-200M LA-250MH LA-200Y LA-250Y LA-250YH	60	1-10 ER16A	20	5000	±90°	100	50.6	65.5	46	14.6	85	40	1601KL-000	DA60-K-16BAC	6.6
	60	1-13 ER20A	26	5000	±90°	100	56.1	65.5	46	15.1	85	40	1601KB-000	DA60-K-20BAC	6.6
NEX-108M /FX-800	60	1-10 ER16A	20	5000	±90°	100	50.6	65.5	46	14.6	85	32	1601KY-000	S-DA60-K-16BAC	6.6
	60	1-13 ER20A	26	5000	±90°	100	56.1	65.5	46	15.1	85	32	1601KW-000	S-DA60-K-20BAC	6.6

AXIAL MILLING AND DRILLING HEADS DOUBLE HEADS

軸向雙頭鑽銑刀座(0°)

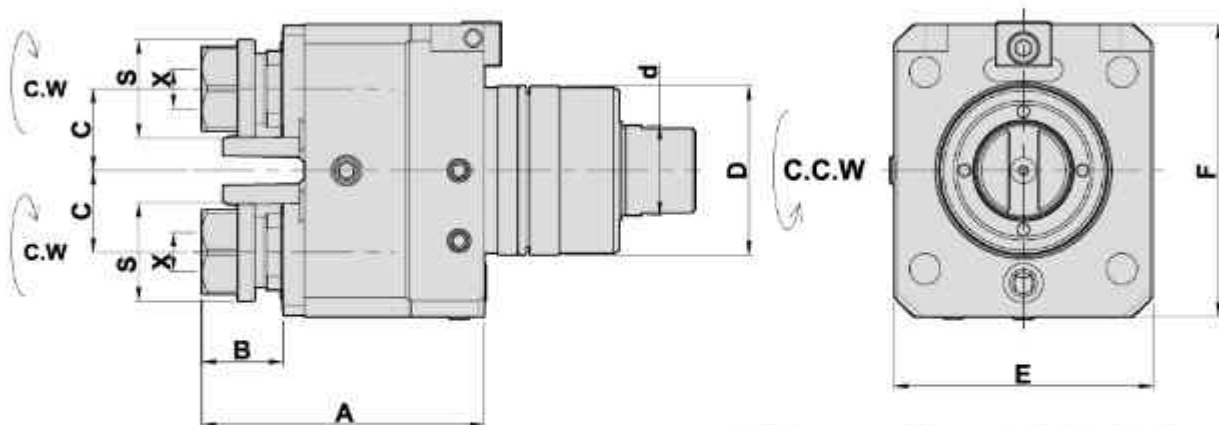

- To be used for collet DIN 6499
- External coolant supply
- Collet is not included

DIMENSIONS

Models	D	X Capacity	S	Maximum R.P.M.	A	B	C	E	F	d	Code No.	Order No.	(Kg) Weight
NEX-108M /FX-800	60	1-13 ER20	35	6000	100.5	29	29	90	104	32	1601KV-000	S-DA60-K-20DZ	5.8

AXIAL MILLING AND DRILLING HEADS DOUBLE HEADS

TYPE TAKISAWA

徑向雙頭鑽銑刀座(90°)

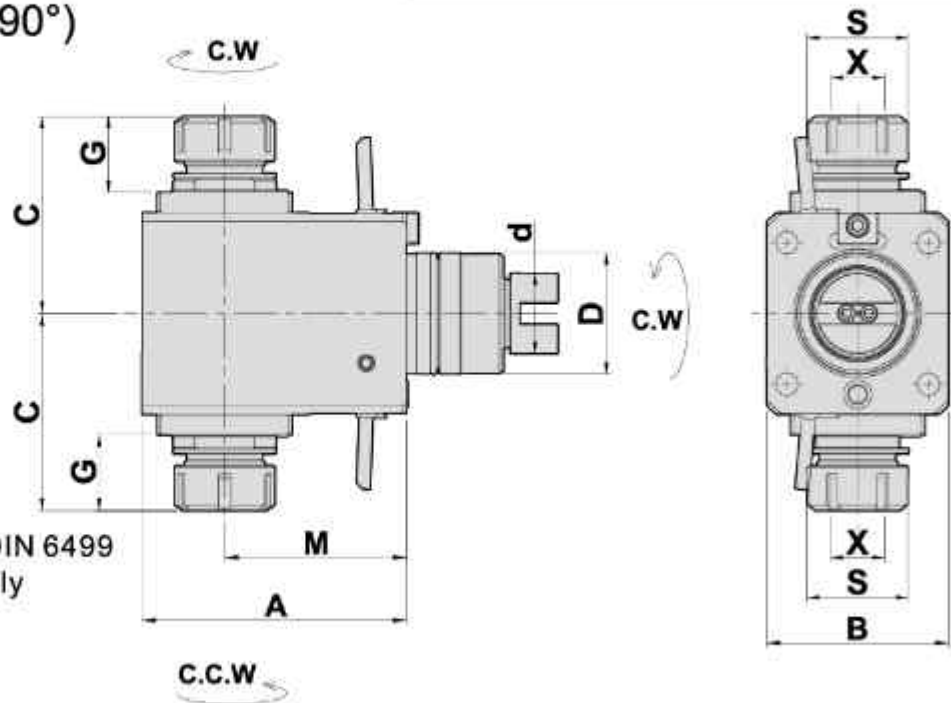

- To be used for collet DIN 6499
- External coolant supply
- Collet is not included

DIMENSIONS

Models	D	X Capacity	S	Maximum R.P.M.	A	B	C	G	M	d	Code No.	Order No.	(Kg) Weight
EX308 LA-200M LA-250MH LA-200Y LA-250YH	60	2-20 ER32	50	5000	131	90	97.5	37.6	90	40	2601KC-000	DF60-K-32-90D	10.4
NEX-108M /FX-800	60	2-20 ER32	50	5000	131	90	97.5	37.6	90	32	2601KU-000	S-DF60-K-32-90D	10.4

AXIAL MILLING AND DRILLING HEAD

軸向鑽銑刀座(0°)

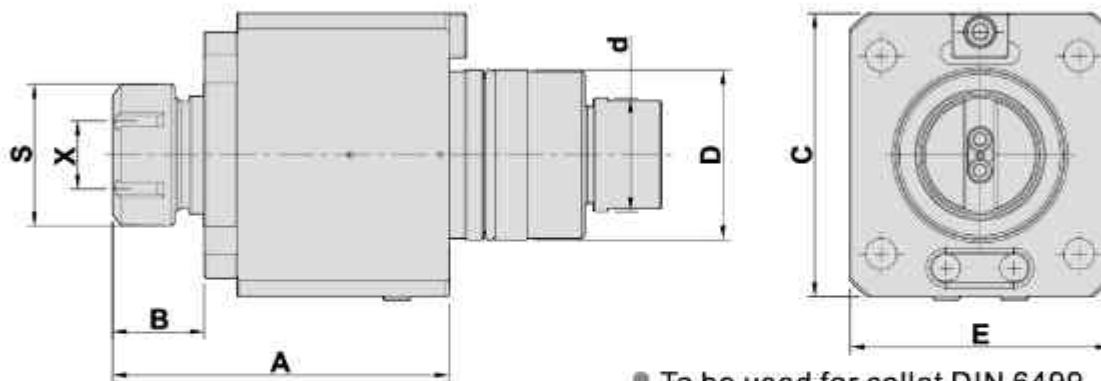

- To be used for collet DIN 6499
- Internal coolant supply: 15bar 中心出水
- Collet is not included

DIMENSIONS

Models	D	X Capacity	S	Maximum R.P.M.	A	B	C	E	d	Code No.	Order No.	(Kg) Weight
EX308 LA-200M LA-250MH LA-200Y LA-250YH	60	2-20 ER32	50	6000	119	32.5	100	92	40	1601KG-000	CW-DA60-K-ER32	6.5

RADIAL MILLING AND DRILLING HEAD

TYPE TAKISAWA

徑向鑽銑刀座(90°)

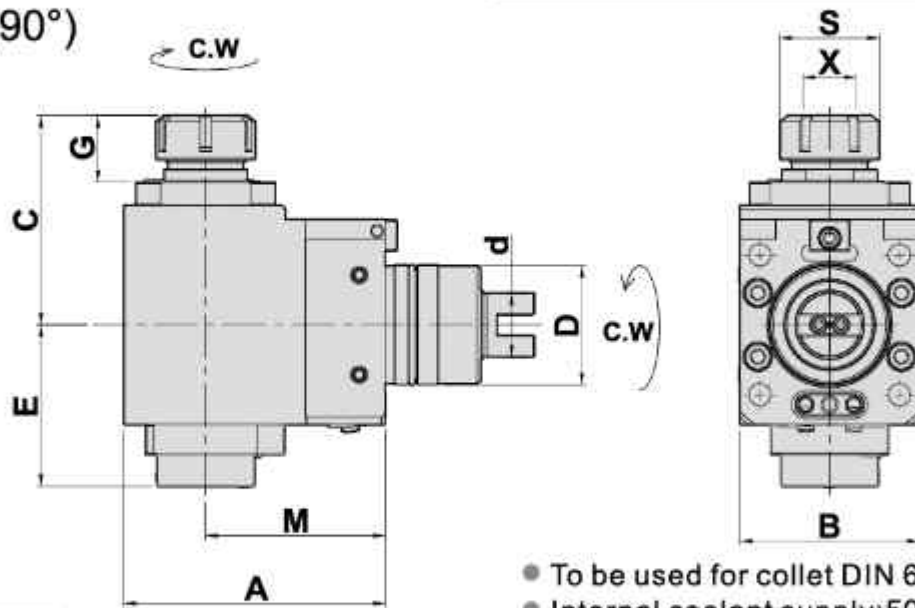

- To be used for collet DIN 6499
- Internal coolant supply: 50bar 中心出水
- Collet is not included

DIMENSIONS

Models	D	X Capacity	S	Maximum R.P.M.	A	B	C	G	E	M	d	Code No.	Order No.	(Kg) Weight
EX308 LA-200M LA-250MH LA-200Y LA-250Y LA-250YH	60	2-20 ER32	50	5000	131	90	105	33.5	81	90	40	2601KD-000	CW-DFL60-K-32-90	11
NEX-108M /FX-800	60	2-20 ER32	50	5000	131	90	105	33.5	81	90	32	2601KA002-000	S-CW-DFL60-K-32-90	11

RADIAL MILLING AND DRILLING HEAD

徑向鑽銑刀座(90°)

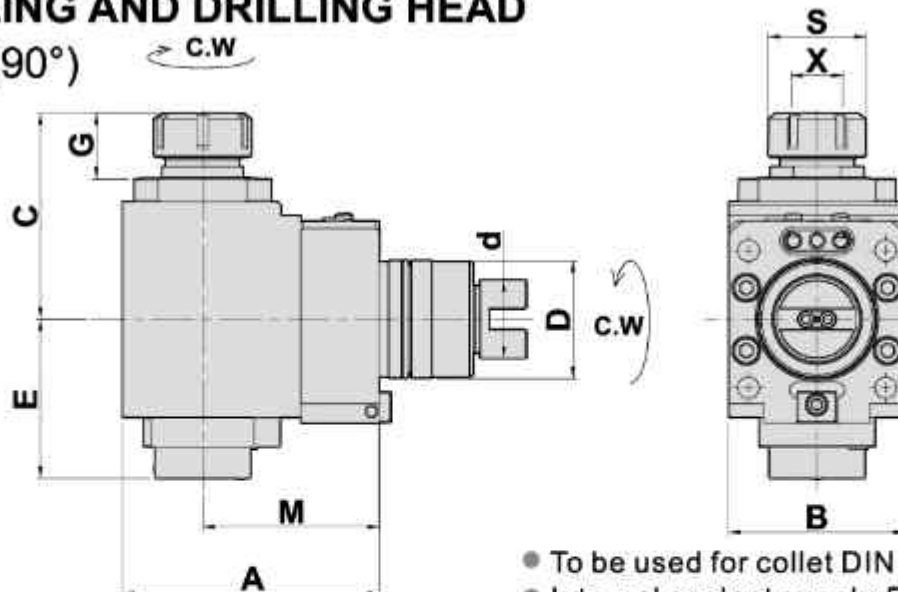

- To be used for collet DIN 6499
- Internal coolant supply: 50bar 中心出水
- Collet is not included

DIMENSIONS

Models	D	X Capacity	S	Maximum R.P.M.	A	B	C	G	E	M	d	Code No.	Order No.	(Kg) Weight
EX308 LA-200M LA-250MH LA-200Y LA-250Y LA-250YH	60	2-20 ER32	50	5000	131	90	105	33.5	81	90	40	2601KV-000	CW-DFR60-K-32-90	11

AXIAL MILLING AND DRILLING HEAD

TYPE TAKISAWA

軸向鑽銑刀座 (0°)

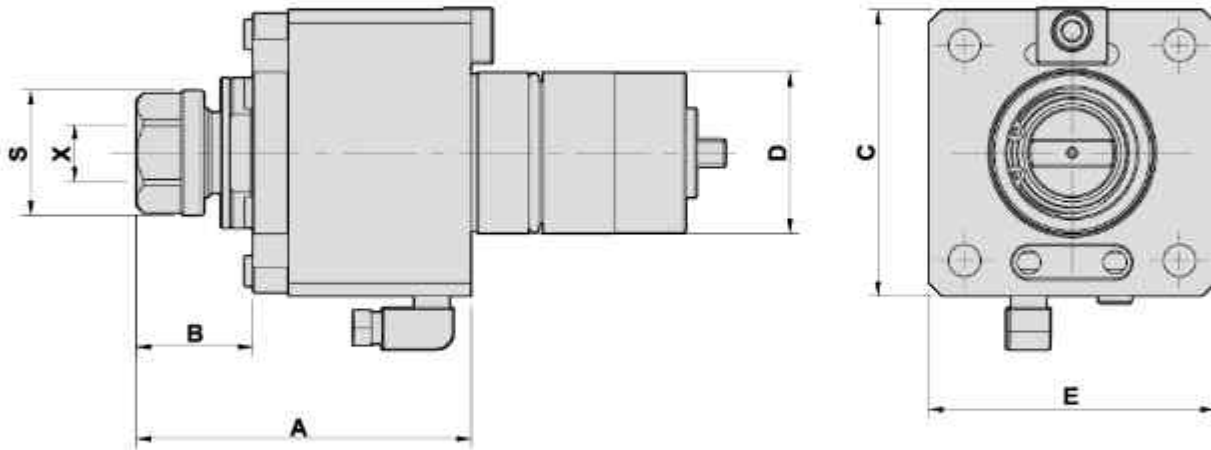

- To be used for collet DIN 6499
- External coolant supply
- Collet is not included

DIMENSIONS

Models	D	X Capacity	S	Maximum R.P.M.	A	B	C	E	Code No.	Order No.	(Kg) Weight
LA-150	45	1-13 ER20	35	6000	93.5	32.5	80	80	1451KA-000	DA45-K-ER20	3.5

RADIAL MILLING AND DRILLING HEAD

徑向鑽銑刀座 (90°)

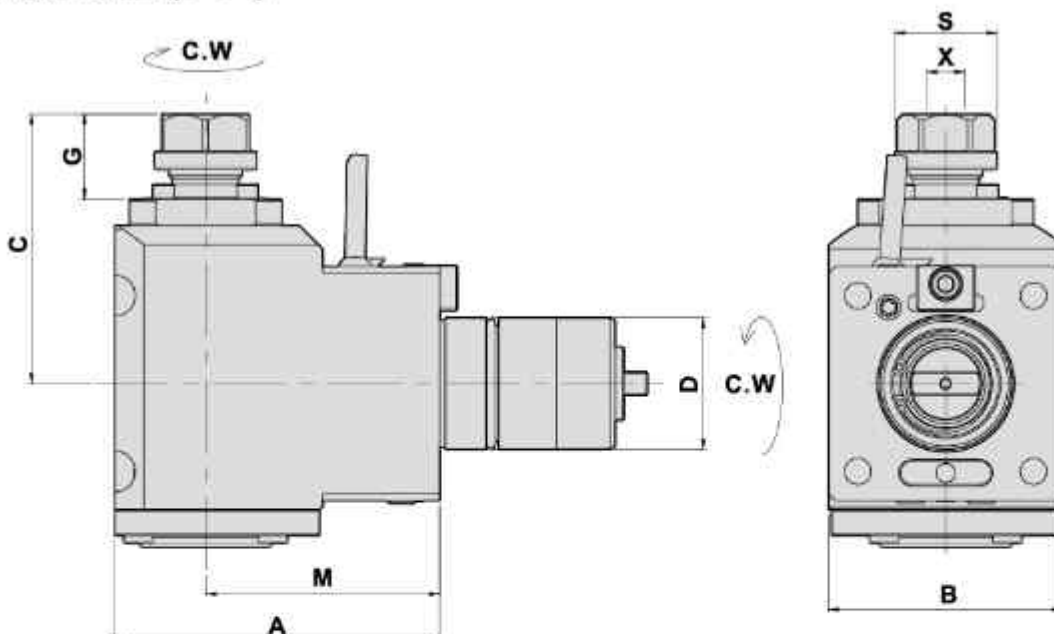

- To be used for collet DIN 6499
- External coolant supply
- Collet is not included

DIMENSIONS

Models	D	X Capacity	S	Maximum R.P.M.	A	B	C	G	M	Code No.	Order No.	(Kg) Weight
LA-150	45	1-13 ER20	35	5000	111	80	92	29	80	2451KA-000	DF45-K-20-80	6.5